

1. Product profile

1-1.General description

The UMH15NTH of digital transistors is designed to replace a single device and its external resistor bias network. The bias resistor transistor contains a single transistor with a monolithic bias network consisting of two resistors; a series base resistor and a base– emitter resistor. The UMH eliminates these individual components by integrating them into a single device. The use of a UMH can reduce both system cost and board space.

1-2. Features

- $BV_{CC} > 50V$
- $I_C = 100mA$ high collector current
- Built-In bias resistors $R_1 = 4.7K\Omega, R_2 = 4.7K\Omega$
- Pair of PNP transistors that are intrinsically matched
- Simplifies circuit design
- Reduce board space
- Reduce component count

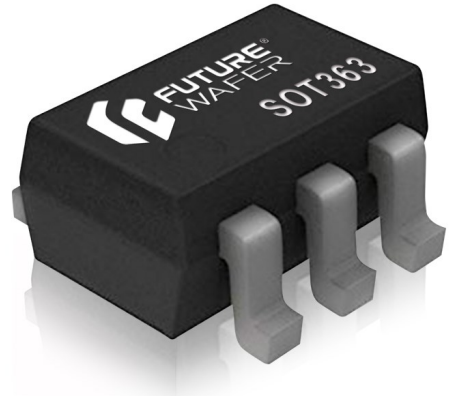

SOT363

1-3. Applications

- Inverter
- Interface
- Driver

1-4. Mechanical characteristics

- Molded SOT-363 package
- Packing:tape and reel
- Flammability rating UL 94V-0
- Halogen free
- Moisture sensitivity levels (MSL): Level 1



2. Maximum ratings

Table 1. maximum ratings

Parameter	Symbol	Value	Units
Supply voltage	V_{CC}	50	V
Input voltage	V_{IN}	-10 to 30	
Output current	I_O	100	mA
Max. collector current	I_C		
Total power dissipation	P_{tot}	150	mW
Junction temperature	T_j	-55 to +150	°C
Storage temperature range	T_{stg}	-55 to +150	

3. Electrical characteristics

Table 3. Electrical characteristics

Parameter	Symbol	Condition	Min.	Typ.	Max.	Units
Input voltage	V_{IN-OFF}	$V_{CC} = 5V, I_O = 100\mu A$	0.5	-	-	V
	V_{IN-ON}	$V_O = 0.3V, I_O = 5mA$	-	-	1.3	
Output voltage	V_{O-ON}	$I_O = 10mA, I_{IN} = 0.5mA$	-	-	0.3	
Input current	I_{IN}	$V_{IN} = 5.0V$	-	-	1.8	mA
Output current	$I_{Q(OFF)}$	$V_{CC} = 50Vdc, V_I = 0V$	-	-	0.5	uA

4. On characteristics

Table 5. On characteristics

Parameter	Symbol	Condition	Min.	Typ.	Max.	Units
DC current gain	h_{FE}	$I_C = 10mA, V_O = 5V$	30	-	-	-
Input resistance	R_1	-	3.29	4.7	6.11	KΩ
Resistance ratio	R_2 / R_1	-	0.8	1	1.2	-

5. Small signal characteristics

Table 6. small signal characteristics

Parameter	Symbol	Condition	Min.	Typ.	Max.	Units
Current gain bandwidth product	f_T	$I_O = 5mA, V_{CE} = 10V, f = 100MHz$	-	250	-	MHz
Collector capacitance	C_C	$V_{CB} = 10V; I_E = I_C = 0A; f = 1MHz$	-	-	2.5	pF

6. Rating and characteristics curve

Fig. 1 Input voltage (off) characteristics

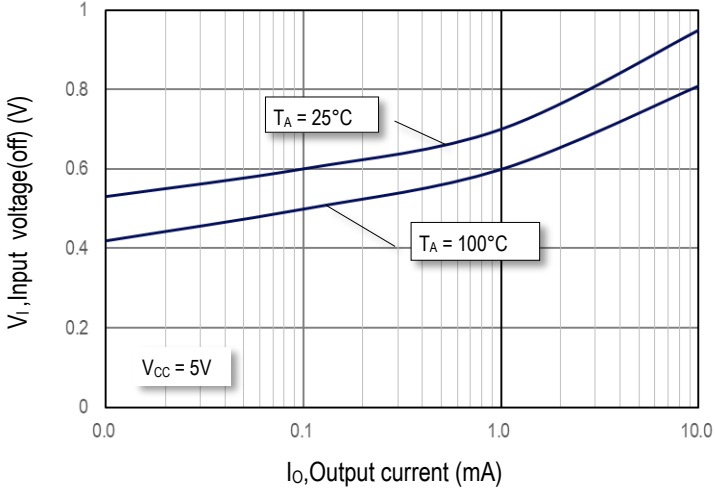

Fig. 2 Output voltage characteristics

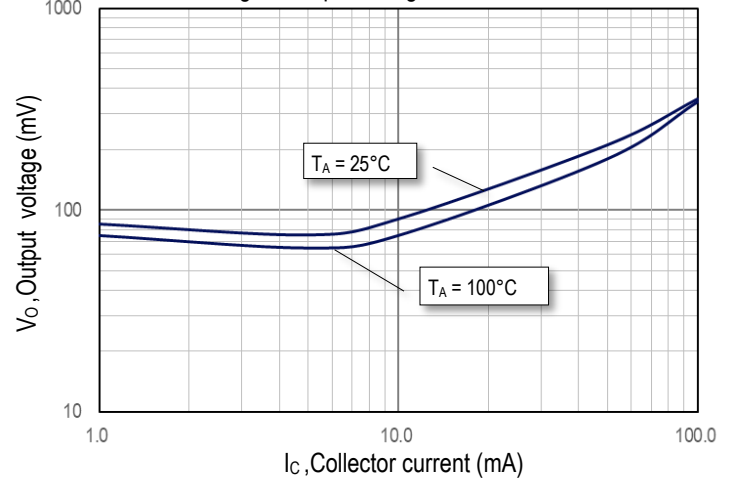

Fig. 3 Power derating curve

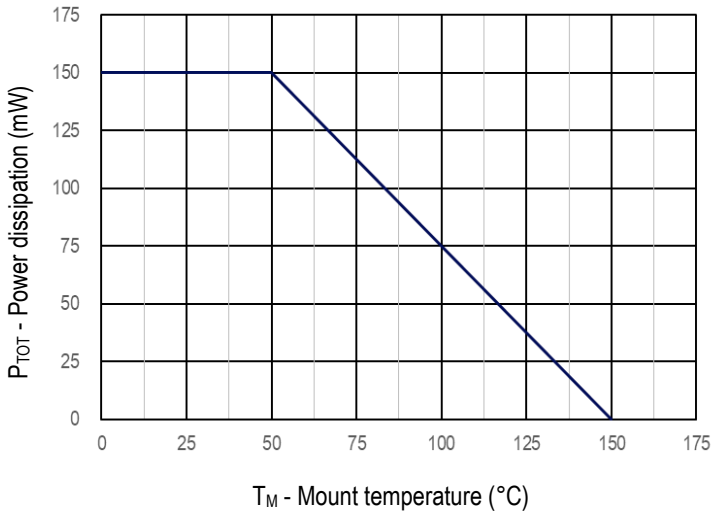

Fig. 4 DC Current gain vs output current

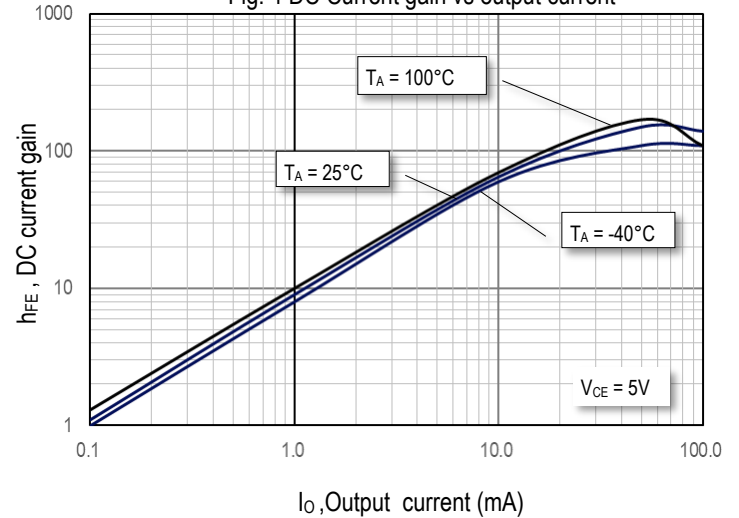

Fig. 5 Input voltage vs output current (On) characteristics

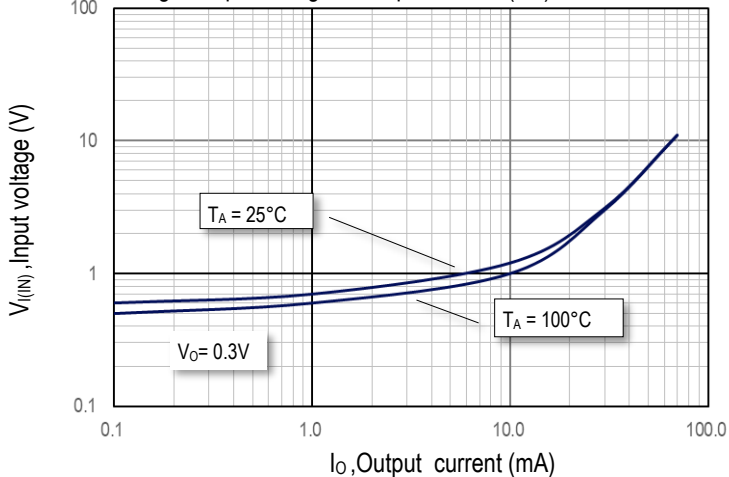
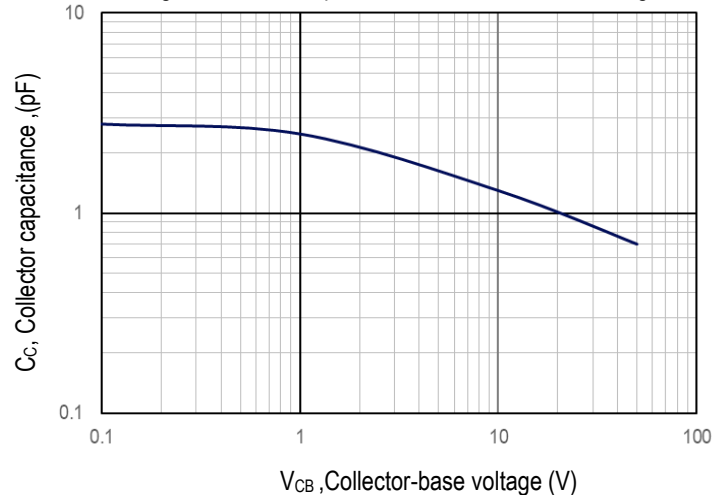

Fig. 6 Collector capacitance of collector-base voltage



7. Recommended reflow soldering profile

7-1. Limiting value

The below temperature profile for moisture sensitivity characterization is based on the IPC/JEDEC joint industry standard: J-STD-020D-01.

Profile Feature	SnPb eutectic assembly	Pb-free assembly
Average ramp-up rate (T _{smax} to T _p)	3 °C/s maximum	3 °C/s maximum
Preheat		
Temperature minimum (T _{smin})	100 °C	150 °C
Temperature maximum (T _{smax})	150 °C	200 °C
Time (t _{smin} to t _{smax})	60 s to 120 s	60 s to 180 s
Time maintained above		
Temperature (T _L)	183 °C	217 °C
Time (t _L)	60 s to 150 s	60 s to 150 s
Peak/classification temperature (T)	235 °C	260 °C
Number of allowed reflow cycles	3	3
Time within 5 °C of actual peak temperature (t _p)	10 s to 30 s	20 s to 40 s
Ramp-down rate	6 °C/s maximum	6 °C/s maximum
Time 25 °C to peak temperature	6 minutes maximum	8 minutes maximum

7-2. Reflow soldering profile

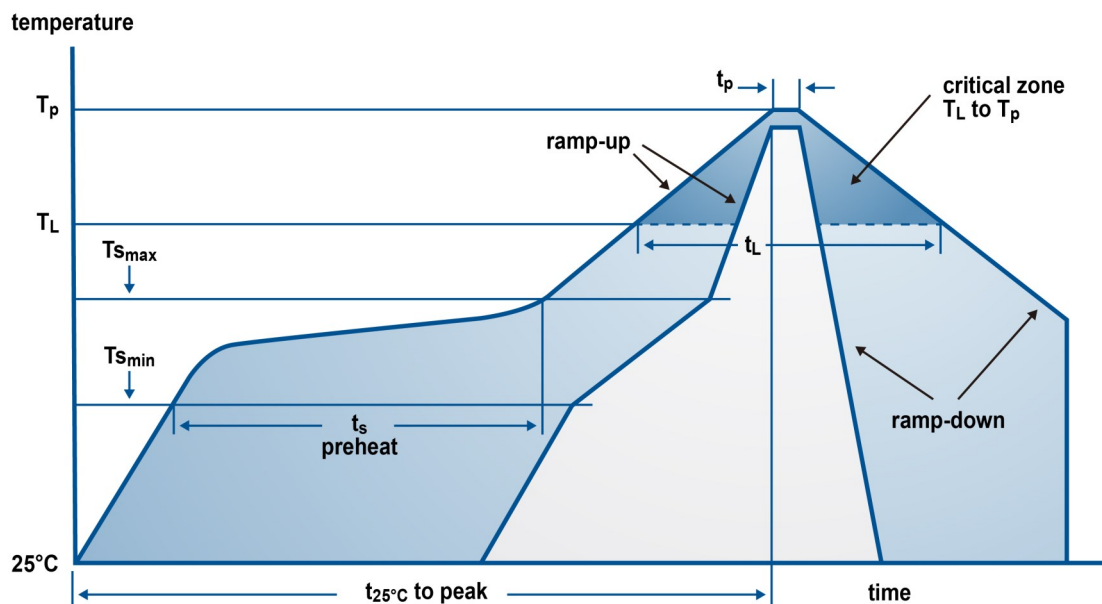

All information hereunder is per Futurewafer Tech' best knowledge. In case Futurewafer Tech has tested the product, This documentation reflects The outcome of the analysis of the actually tested parts only. This document does not provide for any representation or warranty express or implied by Futurewafer Tech. applications and test results, analysis or assessments that are described herein are for illustrative purposes only. Futurewafer Tech makes no representation or warranty neither that such applications will be suitable for the specified use nor that the information, test results, analysis or assessments are reliable without further testing or modification through customer.

8. Package information

8-1. Dimension

Plastic surface-mounted package ; 6 Leads

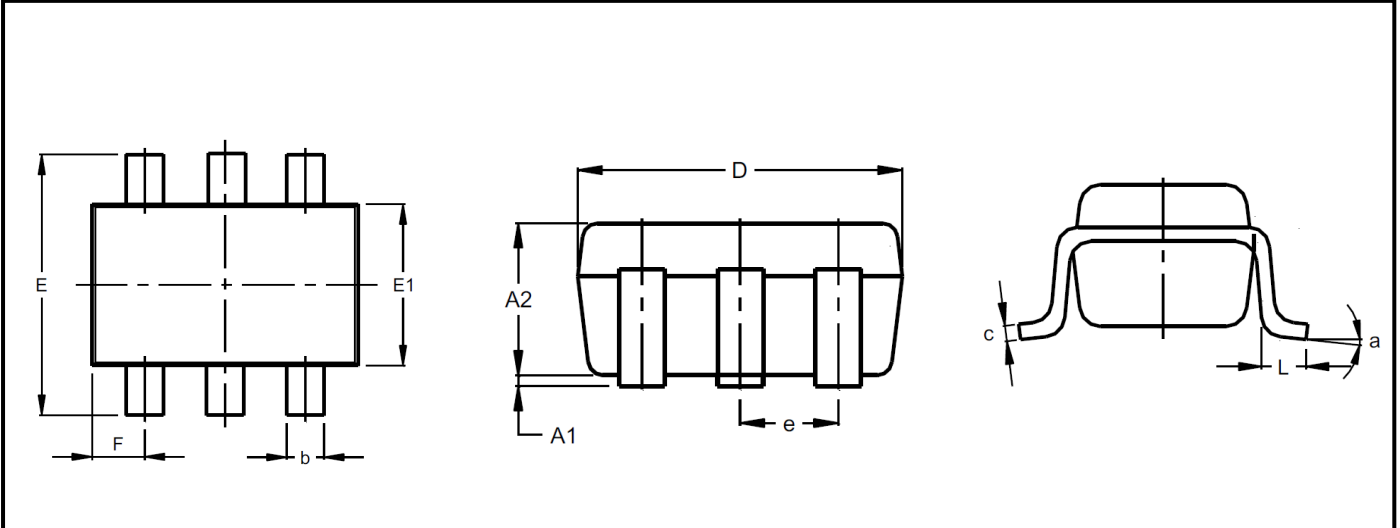

Table 7. Package summary

Dimension in mm

Dim	A1	A2	b	c	D	E	E1	e	F	L	a
Min	0.00	0.9	0.10	0.10	1.8	2.0	1.15	-	0.40	0.20	-
Typ	-	-	-	-	-	-	-	0.65	-	-	-
Max	0.10	1.0	0.30	0.22	2.2	2.2	1.35	-	0.45	0.40	8°

8-2. PCB Pad layout recommendation

Reflow soldering footprint for SOT-363

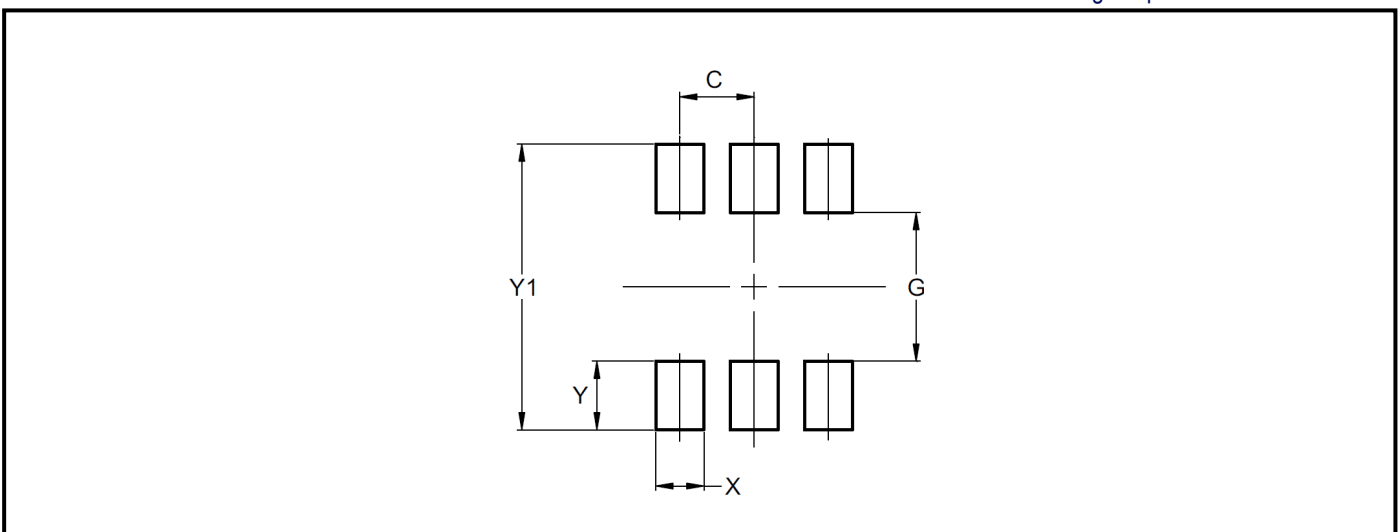

Table 8. layout summary

Dimension in mm

Dim	C	G	X	Y	Y1
Value	0.65	1.30	0.42	0.60	2.50

9. Packing

9-1. Taping and reel specification

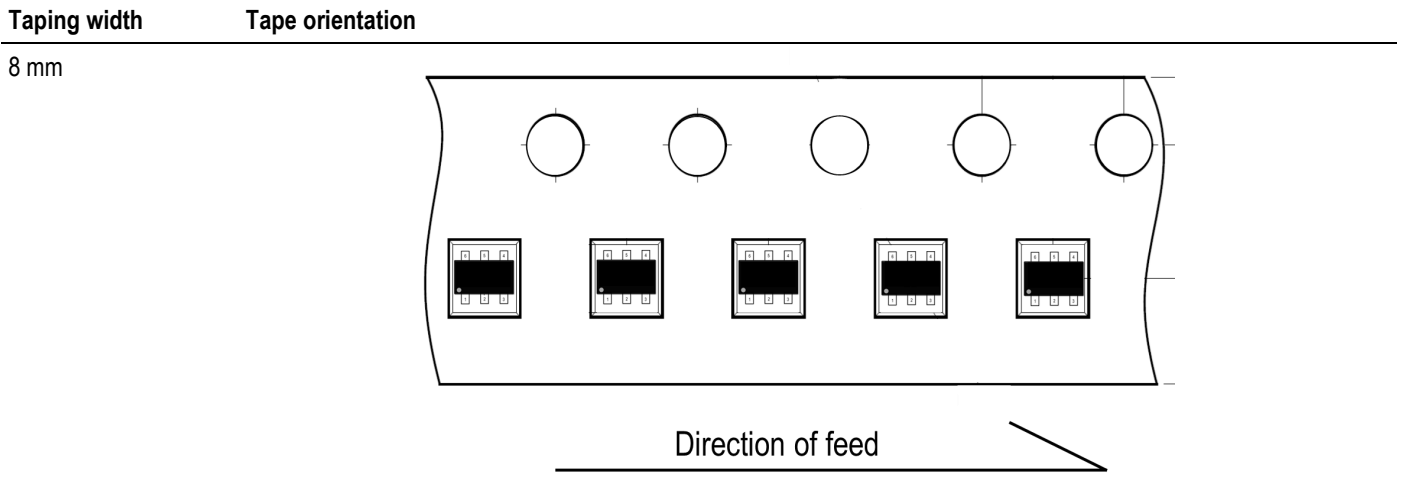

9-2. Embossed carrier tape specification

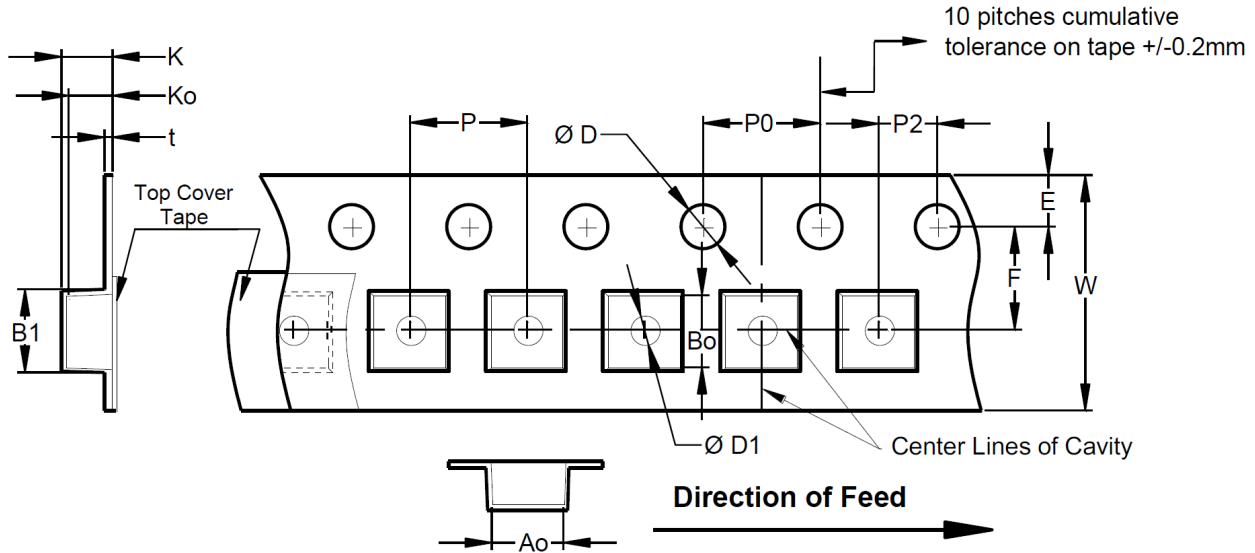

Table 9. tape summary

Dimension in mm

Dimension	W	B1	D	D1	E	F	K	P	P0	P2	t	W
Value	8 mm	4.5 Max	1.5+ 0.1/-0.0	0.35 Min.	1.75 ±0.10	3.5 ±0.05	2.4 Max.	4.0 ±0.10	4.0 ±0.10	2.0 ±0.05	0.4 Max.	8 ±0.3
A0 / B0 / K0	Determined by component size. The clearance between the component and the cavity must comply to the rotational and lateral movement requirement provided in figures in the "maximum component movement in tape pocket" section.											

10. Surface mount reel specification

10-1. Reel specification

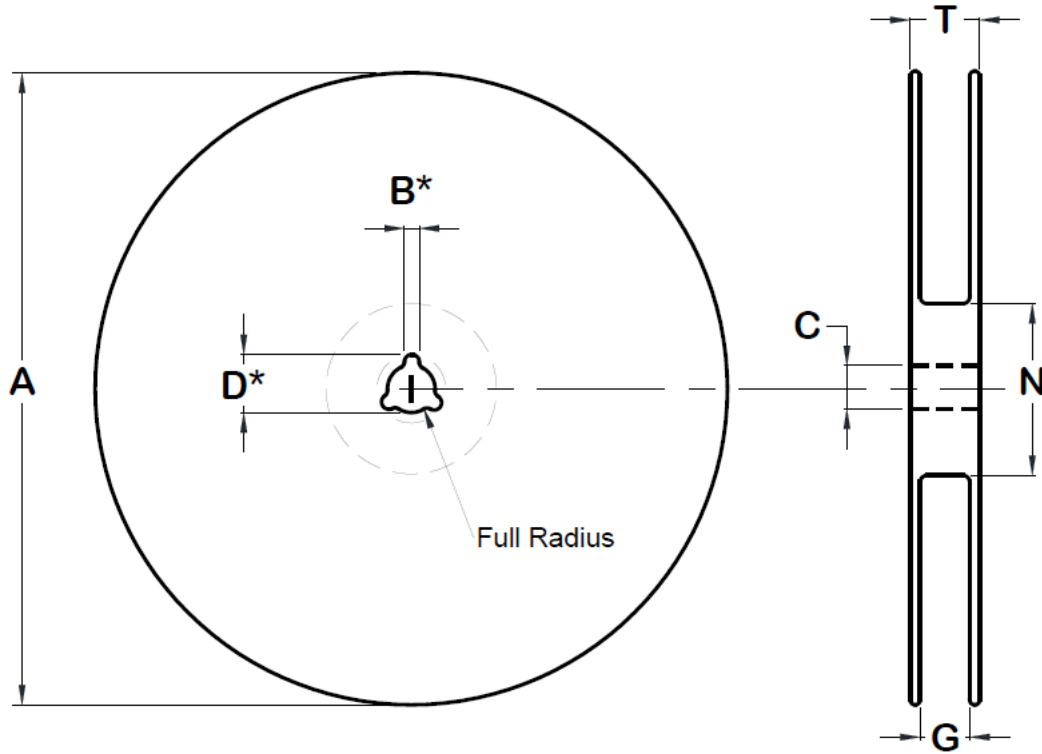
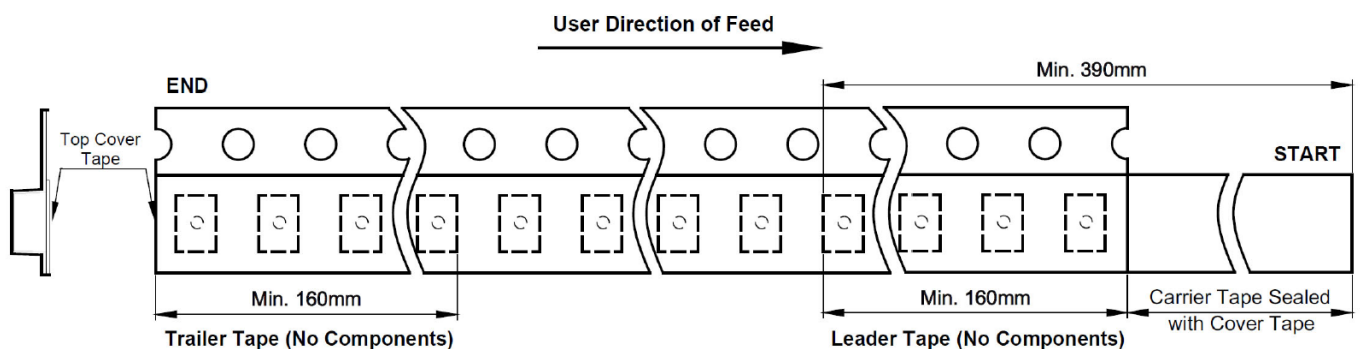

Table 10. Reel information

Unit : mm

Dimension	Tape width	Reel size	A	B	C	D	N	G	T
Value	8 mm	7"	178	2.0	13	20.5	55	8.4	14.4
			±2	+0.5-0	+0.5-0.2	±0.2	±5	+1.5/ -0.0	Max.

10-2. Tape leader and trailer specification



11. Ordering information

Table 11. Ordering information

Part number	Package name	Description	Packing
UMH15NTH	SOT-363	Plastic surface-mounted package; 6 leads	3,000 Pcs / 7" tape and reel

12. Marking information

Table 12. Marking codes

Part number	Marking code
UMH15NTH	H15

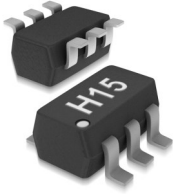

13. Pinning information

Table 13. Pinning information

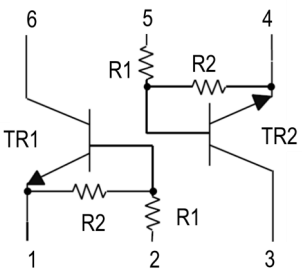
Pin	Symbol	Description	Simplified outline	Graphic symbol
1	E 1	Emitter 1		
2	B 1	Base 1		
3	C 2	Collector 2		
4	E 2	Emitter 2		
5	B 2	Base 2		
6	C 1	Collector 1		

14. Legal information

Definitions

Draft — The document is a draft version only. The content is still under internal review and subject to formal approval, which may result in modifications or additions. Futurewafer does not give any representations or warranties as to the accuracy or completeness of information included herein and shall have no liability for the consequences of use of such information.

Disclaimers

Limited Warranty And Liability — Information in this document is believed to be accurate and reliable. However, Futurewafer does not give any representations or warranties, expressed or implied, as to the accuracy or completeness of such information and shall have no liability for the consequences of use of such information. Futurewafer takes no responsibility for the content in this document if provided by an information source outside of Futurewafer. In no event shall Futurewafer be liable for any indirect, incidental, punitive, special or consequential damages (including - without limitation - lost profits, lost savings, business interruption, costs related to the removal or replacement of any products or rework charges) whether or not such damages are based on tort (including negligence), warranty, breach of contract or any other legal theory. Notwithstanding any damages that customer might incur for any reason whatsoever, Futurewafer's aggregate and cumulative liability towards customer for the products described herein shall be limited in accordance with the terms and conditions of commercial sale of Futurewafer.

Right to make changes — Futurewafer reserves the right to make changes to information published in this document, including without limitation specifications and product descriptions, at any time and without notice. This document supersedes and replaces all information supplied prior to the publication here of.

Suitability for use — Futurewafer products are not designed, authorized or warranted to be suitable for use in life support, life-critical or safety-critical systems or equipment, nor in applications where failure or malfunction of an Futurewafer product can reasonably be expected to result in personal injury, death or severe property or environmental damage. Futurewafer and its suppliers accept no liability for inclusion and/or use of Futurewafer products in such equipment or applications and therefore such inclusion and/or use is at the customer's own risk.

Applications — applications that are described herein for any of these products are for illustrative purposes only. Futurewafer makes no representation or warranty that such applications will be suitable for the specified use without further testing or modification. Customers are responsible for the Design and operation of their applications and products using Futurewafer products, and Futurewafer accepts no liability for any assistance with applications or customer product design. It is customer's sole responsibility to determine whether the Futurewafer product is suitable and fit for the customer's applications and products planned, as well as for the planned application and use of customer's third party customer(s). customers should provide appropriate design and operating safeguards to minimize the risks associated with their applications and products.

Futurewafer does not accept any liability related to any default, damage, costs or problem which is based on any weakness or default in the customer's applications or products, or the application or use by customer's third party customer(s). customer is responsible for doing all necessary testing for the customer's applications and products using Futurewafer products in order to avoid a default of the applications and the products or of the application or use by customer's third party customer(s). Futurewafer does not accept any liability in this respect.

Export control — This document as well as the item(s) described herein may be subject to export control regulations. export might require a prior authorization from competent authorities.

Translations — A non-English (translated) version of a document is for reference only. The English version shall prevail in case of any discrepancy between the translated and English versions.

15. Revision history

Table 14. Revision history

Version	Document ID	Release date	Change notice	Basis
A	F51830X	03-Aug-2018	New develop	Market
4.0		24-Mar-2023	Update version	System